

ROADMACHINE 01 / ROADMACHINE

- Frame** Roadmachine (01) Premium Carbon with TCC Endurance
- ICS Technology, sealth cable routing
 - PF86 bottom bracket
 - Integrated seatpost clamp
 - Flat mount disc
 - 12x142 mm thru-axle
- Fork** Roadmachine (01) Premium Carbon With TCC Endurance
- ICS Technology, sealth cable routing
 - Flat mount disc
 - 12x100 mm thru-axle
 - 50 mm offset (size 47-51), 45 mm offset (size 54-61)
- Seatpost** Roadmachine 01 Premium Carbon D-shape Seatpost
- 15 mm offset

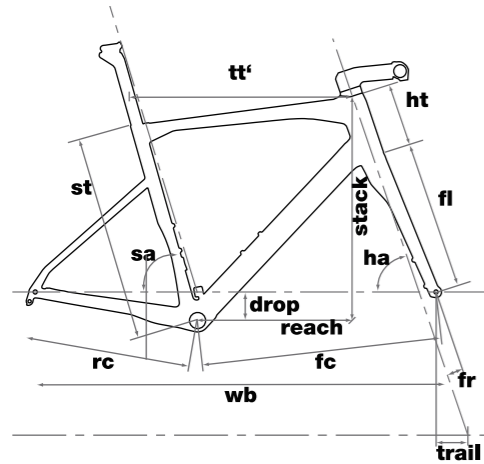

ROADMACHINE 01

Size	47	51	54
Rider Height cm	<166	166-174	172-180
Stack	516	541	562
Reach	374	382	386
Seat Tube (st)	420	457	500
Top Tube (tt')	522	532	546
Head Tube (ht)	112	139	156
Seat Angle ° (sa)	74.2	74.2	74.2
Head Angle ° (ha)	71.2	71.2	72
Rear Center (rc)	410	410	410
Front Center (fc)	583	599	597
Wheelbase (wb)	982	999	997
BB Drop (drop)	71	71	71
Fork Length (fl)	375	375	375
Fork Rake (fr)	50	50	45
Trail	63	63	63
Crank Length	170	170	172.5
Stem Length (ICS2)	90	90	100
Stem Angle ° (ICS2)	-12.5	-12.5	-12.5
Bar Width	400	420	420
Bar Drop (RCB02)	125	125	125
Bar Reach (RCB02)	70	70	70
Seatpost Length	330	380	380
Seatpost Offset	15	15	15
Standover Height	719	750	782

※ 特記がない場合は、mm単位での表記となります。

Roadmachine X Carbon

- Frame** Roadmachine X Premium Carbon with TCC Endurance
- PF86 bottom bracket
 - Integrated seatpost clamp
 - Flat mount disc
 - 12x142 mm thru-axle
- Fork** Roadmachine X Premium Carbon With TCC Endurance
- Flat mount disc
 - 12x100 mm thru-axle
 - 50 mm offset (size 47-51), 45 mm offset (size 54-61)
- Seatpost** Roadmachine X Premium Carbon D-shape Seatpost
- 15 mm offset

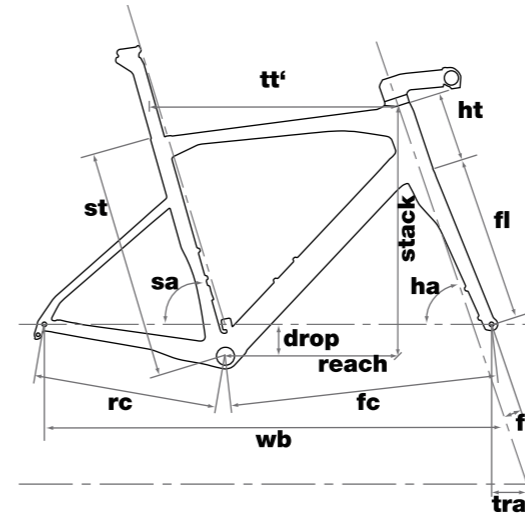

Roadmachine X Carbon

Size	47	51
Rider Height cm	<166	166-174
Stack	516	541
Reach	374	382
Seat Tube (st)	420	457
Top Tube (tt')	522	532
Head Tube (ht)	112	139
Seat Angle ° (sa)	74.2	74.2
Head Angle ° (ha)	71.2	71.2
Rear Center (rc)	410	410
Front Center (fc)	583	599
Wheelbase (wb)	982	999
BB Drop (drop)	71	71
Fork Length (fl)	375	375
Fork Rake (fr)	50	50
Trail	63	63
Crank Length	170	170
Stem Length	80	90
Stem Angle °	±0	±0
Bar Width	400	420
Bar Drop	125	125
Bar Reach	70	70
Seatpost Length	330	380
Seatpost Offset	15	15
Standover Height	719	750

※ 特記がない場合は、mm単位での表記となります。

Roadmachine

Size	47	51	54	57
Rider Height cm	<166	166-174	172-180	178-186
Stack	516	541	562	586
Reach	374	382	386	390
Seat Tube (st)	440	457	500	522
Top Tube (tt')	522	532	546	556
Head Tube (ht)	112	139	156	181
Seat Angle ° (sa)	74.2	74.2	74.2	74.2
Head Angle ° (ha)	71.2	71.2	72	72
Rear Center (rc)	410	410	410	410
Front Center (fc)	583	599	597	609
Wheelbase (wb)	982	999	997	1008
BB Drop (drop)	71	71	71	71
Fork Length (fl)	375	375	375	375
Fork Rake (fr)	50	50	45	45
Trail	63	63	63	63
Crank Length	170	170	172.5	172.5
Stem Length	90	90	100	110
Stem Angle °	±8	±8	±8	±8
Bar Width	400	420	420	420
Bar Drop	125	125	125	125
Bar Reach	70	70	70	70
Seatpost Length	330	380	380	380
Seatpost Offset	15	15	15	15
Standover Height	tbd	tbd	tbd	tbd

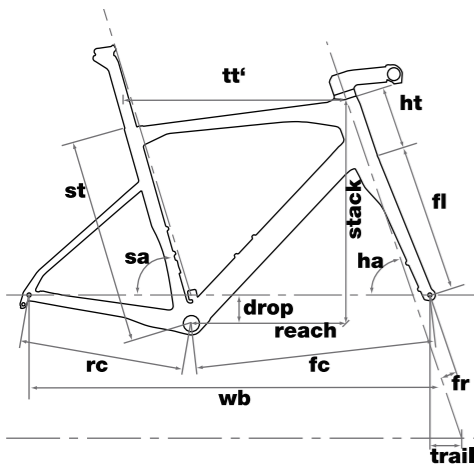

※ 特記がない場合は、mm単位での表記となります。

Roadmachine X AL

- Frame** Roadmachine X Premium Aluminium with Gravel+ Geometry
- PF86 bottom bracket
 - Fender & rack mounts
 - Flat mount disc
 - 12x142 mm thru-axle
- Fork** Roadmachine X Carbon
- Flat mount disc
 - 12x100 mm thru-axle
 - Fender & cargo mounts
- Seatpost** BMC RSP03
- Dia. 27.2 mm & 0 mm offset

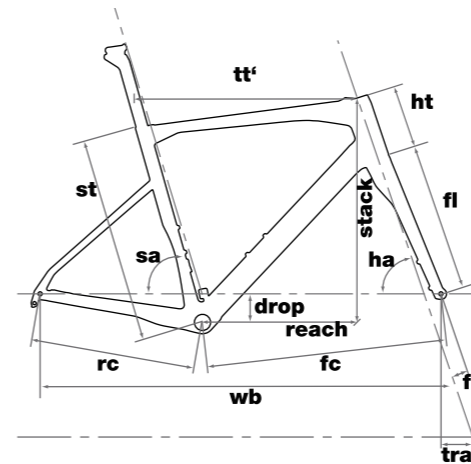

Roadmachine X AL

Size	XS	S	M
Rider Height cm	<165	162-172	172-182
Stack	525	550	580
Reach	390	400	410
Seat Tube (st)	430	455	475
Top Tube (tt')	540	558	576
Head Tube (ht)	92	118	150
Seat Angle ° (sa)	74	74	74
Head Angle ° (ha)	70	70	70
Rear Center (rc)	430	430	430
Front Center (fc)	608	626	647
Wheelbase (wb)	1028	1047	1068
BB Drop (drop)	69	69	69
Fork Length (fl)	410	410	410
Fork Rake (fr)	45	45	45
Trail	78	78	78
Crank Length	170	170	172.5
Stem Length	90	90	100
Stem Angle °	±8	±8	±8
Bar Width	400	420	420
Bar Drop	125	125	125
Bar Reach	70	70	70
Seatpost Length	350	350	350
Seatpost Offset	15	15	15
Standover Height	720	738	768

※ 特記がない場合は、mm単位での表記となります。